

### Fitting instructions for Following

- Bathroom Lock
- 6 Lever Lock
- Euro Profile Dead Lock
- Euro Profile Cylinder Lock Body
- Flat Latch
- Euro Profile Sash Lock Body
- Euro Profile Latch Body
- Euro Profile Dead Bolt

### Tools required

- Drill and Drill bits
- Mallet
- Chisel
- Posidrive Screwdriver
- Pencil
- Masking Tape

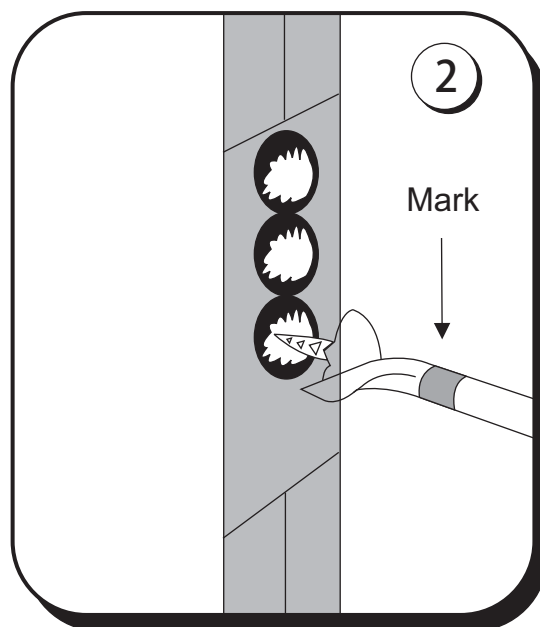
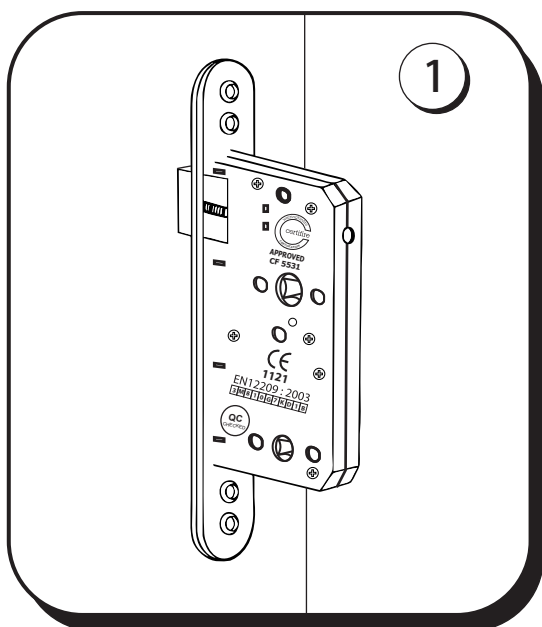

### Preparation to the Door.

1. Position the lock body as near to the mid maximum height 1100mm from bottom & door for fire door assembly of the door as possible, making sure that the proposed morticed hole avoids cutting through doorframe joints. Place the lock body against and across the door edge and mark the top and bottom of the lock case as illustrated.
2. Along the door edge mark a vertical line central to the door thickness, which is used as a central guideline for a series of holes to be drilled to the required depth.  
The required depth = lock body depth + Fixed Forend thickness. Helpful Hints - Mark the "drill-bit" using adhesive tape or a suitable visible marker  
The hole centres should be slightly less than the drill diameter in order that the drilled holes overlap.

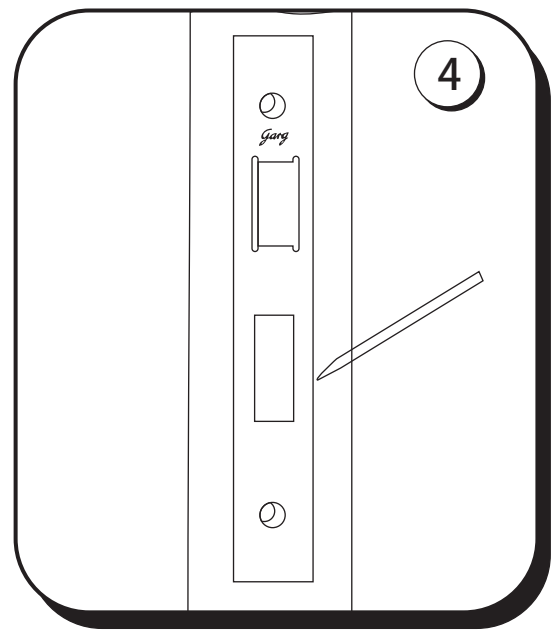
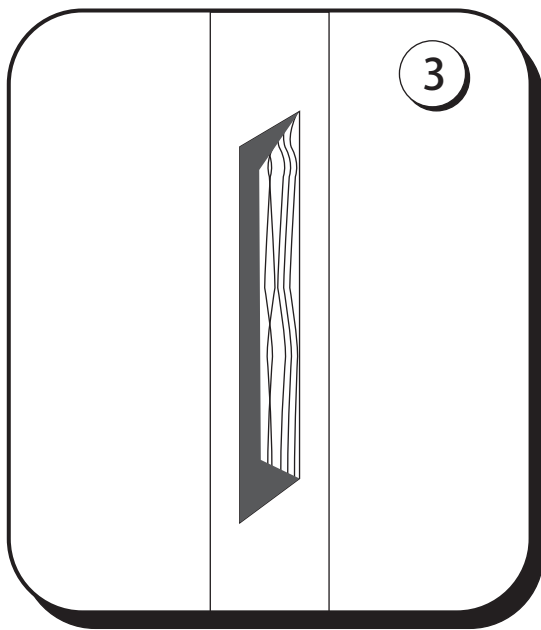

3. Chisel out the remaining wood to provide satisfactory fitment for the lock body.
4. Insert the lock body into the prepared morticed area, temporarily screw the faceplate into position and mark around the lock faceplate and chisel out a recess to accept fixed forend ensuring that when finally fitted the face plate is flush with the door edge. IMPORTANT - With the lock fitted check that the angled or bevelled edge of the latch bolt is facing the doorframe when closing. To Reverse latchbolt insert screw drive push & turn / rotate desired handing & release gently so latch fits snugly in position.

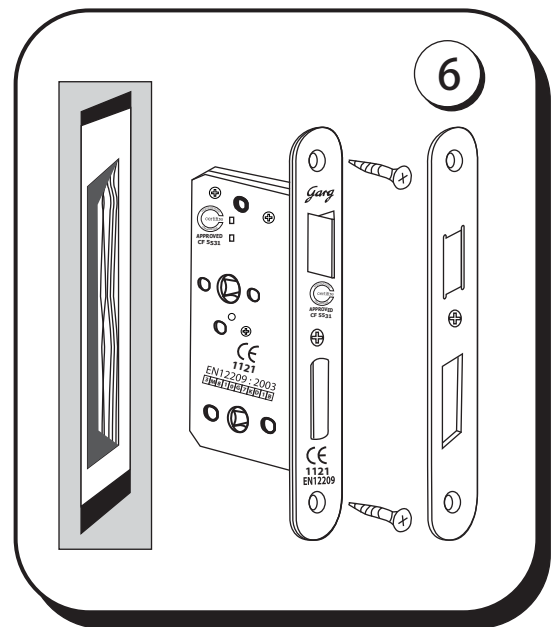
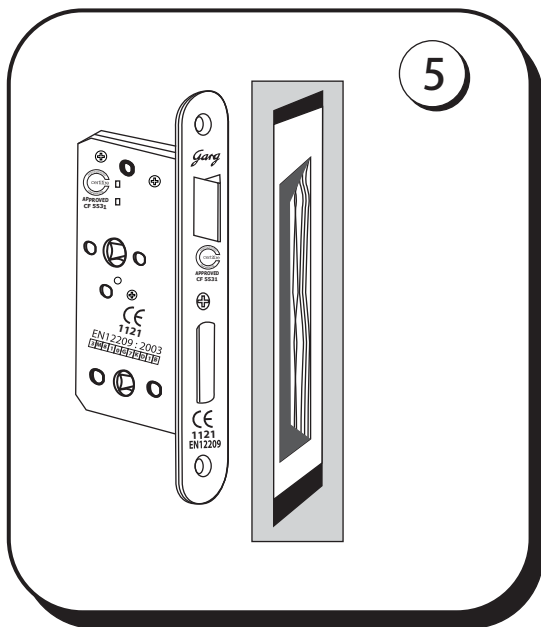

5. Place the lock body against the door face and in line with the lock recess making sure that allowance is made for the faceplate, mark through and drill the hole positions for the Spindle (Sashlock). Euro profile / oval profile cylinder or spindle for snib turn.
6. Fix the lock complete into the door with the screws provided ensuring the key, cylinder and spindle pass through freely into the lock. Fix escutcheons and or handles, making sure to cut the spindle to the required length. Test the final fitting ensuring that the Latch and / or Deadbolt freely operates.

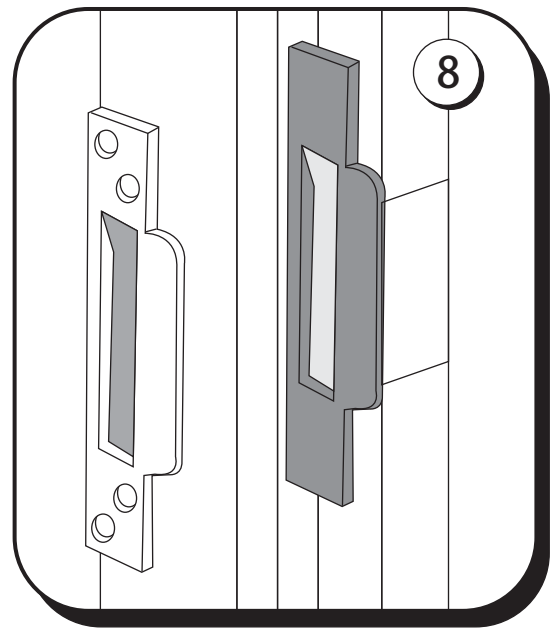
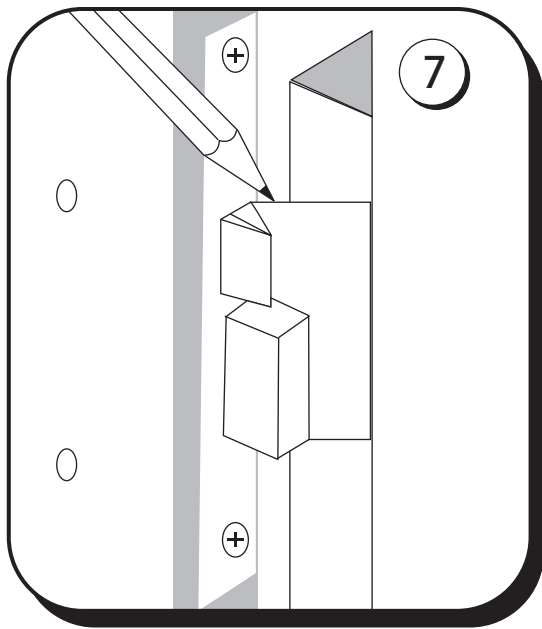

### Fixing the Box or Flat Striker

7. When the lock is fitted, with the door in the open position, turn the key to operate the dead bolt into the "locked position", gently close the door against the frame and mark on the doorframe the top edge of the latch bolt and bottom edge of the dead bolt.
8. Transfer these two marks across to the inside face of the doorframe rebate. Mark an additional horizontal line approximately 2mm above the top line. This line represents the top inside edge of the aperture within the striker and will provide operating clearance. To determine the horizontal position of the striker retract the dead bolt and close the door, applying a little pressure, mark a line on the inside rebate face against the flat face of the latch bolt. This line determines the outside striking edge of the "striker aperture". (See diagram 8). With the final position established mark around the Dust Box or Box Striker and drill a series of holes to the required depth removing excess wood with a chisel. Insert the dust cover and place over the striker forend (or box striker), mark around the outside of the forend and chisel the recess, ensuring the depth is sufficient for the striker face to be flush with the inside rebate frame.

**Maintenance Instructions.:** Keep Lubricating with WD 40 or equivalent lubricant after every 25000 cycle to ensure optimum performance.

For use on fire doors product must be fitted with intumescent pad ( 1mm - 30min, 2mm-60min)



**D.P. Garg & Company Pvt. Ltd.**  
B-210B, Phase-2,  
Noida - 201305 (U.P.) India  
Ph. No.: +91-120-2460091, 2460085-87  
Fax. 91-120 2460083

20

Bathroom Lock	1121-CPR-AG-5151	<b>BS EN 12209 : 2003</b>	2	M	4	1	0	F	0	B	G	1	0
6 Lever Lock	1121-CPR-AG-5210	<b>BS EN 12209 : 2003</b>	1	M	7	1	0	F	2	K	D	1	A
Euro Profile Dead Lock	1121-CPR-AG-5148	<b>BS EN 12209 : 2003</b>	2	M	4	1	0	F	2	B	C	0	0
Euro Profile Cylinder Lock Body	1121-CPR-AG-5210	<b>BS EN 12209 : 2003</b>	1	M	7	1	0	F	1	B	0	1	0
Flat Latch	1121-CPR-AG-5210	<b>BS EN 12209 : 2003</b>	1	M	7	1	0	F	-	B	0	1	0
Euro Profile Sash Lock Body	1121-CPR-AG-5151	<b>BS EN 12209 : 2003</b>	2	M	4	1	0	F	2	B	C	1	0
Euro Profile Latch Body	1121-CPR-AG-5151	<b>BS EN 12209 : 2003</b>	2	M	4	1	0	F	-	B	0	1	0
Euro Profile Dead Bolt	1121-CPR-AG-5148	<b>BS EN 12209 : 2003</b>	2	M	4	1	0	F	2	B	C	0	0

For Declaration of performance please go to [www.garglocks.co.in](http://www.garglocks.co.in), [www.garglocks.com](http://www.garglocks.com)